

www.vskom.de

OnRISC Alena Hardware Manual

Edition: November 2010



Vision Systems GmbH

Tel: +49 40 528 401 0

Fax: +49 40 528 401 99

Web: www.visionsystems.de

Support: faq.visionsystems.de

The software described in this manual is furnished under a license agreement and may be used only in accordance with the terms of that agreement.

Copyright Notice

Copyright © 2009 Vision Systems. All rights reserved. Reproduction without permission is prohibited.

Trademarks

VScom is a trademark of Vision Systems GmbH. All other trademarks and brands are property of their rightful owners.

Disclaimer

Vision Systems reserves the right to make changes and improvements to its product without providing notice.

Vision Systems provides this document “as is,” without warranty of any kind, either expressed or implied, including, but not limited to, its particular purpose. Vision Systems reserves the right to make improvements and/or changes to this manual, or to the products and/or the programs described in this manual, at any time.

Information provided in this manual is intended to be accurate and reliable. However, Vision Systems assumes no responsibility for its use, or for any infringements on the rights of third parties that may result from its use.

This product might include unintentional technical or typographical errors. Changes are periodically made to the information herein to correct such errors, and these changes are incorporated into new editions of the publication.

Contents

1	Overview	4
1.1	Product Features	4
1.2	Hardware Specifications	5
1.2.1	System	5
1.2.2	Serial Ports	5
1.2.3	Digital I/O	6
2	Position of Connectors and Functions	7
2.1	LEDs	8
2.2	Reset Button	8
3	Dimensions	9
4	Connectors	10
4.1	Power	10
4.2	Grounding	10
4.3	LAN	10
4.4	Serial	10
4.5	CAN	10
4.6	Console Port	11
4.7	CF-Slot	11
4.8	microSD-Slot	11
4.9	USB	11
4.10	Digital I/O	11
4.11	I ² C	12
5	Product Support Information	13

List of Figures

1	Appearance	7
2	Case	9

List of Tables

1	Product Hardware Specifications	5
2	Serial Interface Specifications	6
3	LED Indicators	8
4	DSUB Pinout	11

1 Overview

The OnRISC Alena is an ARM9-based RISC industrial embedded computer. The great variety of interfaces like LAN, CAN, CF, USB, I²C, serial interface and digital I/O makes it easy to connect various industrial devices to the OnRISC Alena.

Compact dimensions and DIN Rail mounting capability make the OnRISC Alena to a space saving and flexible mounting industrial computer. It is feasible to be installed even in space limited environments.

Due to RISC based architecture the OnRISC Alena has very small power consumption (6,5 Watt), so fanless heat dissipation is possible. Working in an extended temperature range from -10°C up to 65°C the OnRISC Alena can be used under harsh industrial conditions. Therefore the OnRISC Alena is downright designed for industrial automation.

1.1 Product Features

- ARM9 32-bit RISC CPU, 166MHz
- 64MB SDRAM on board
- 4MB Flash on board
- 2 x RS232/RS422/RS485 serial ports
- 2 x RS232 serial ports
- 1 x CAN port
- 4 independent digital I/O channels
- 2 optically isolated digital input channels
- 2 relays
- 1 x CF-Slot in True IDE mode (accepts MicroDrives)
- 1 x microSD-Slot
- 2 x USB 2.0 as Host
- MiniPCI-slot for expansion with WLAN, GPS etc.
- 2 x Ethernet interfaces for redundant networking or routing functions
- I²C bus with max. 330kHz clock
- RTC
- Ready-to-Run Debian Linux for ARM operating system
- DIN-Rail and wall-mount installation
- Robust, fanless design
- Wide temperature range -10 to 65°C
- Buzzer, Watch Dog Timer

1.2 Hardware Specifications

1.2.1 System

	OnRISC Alena
CPU	ARM9 32-bit RISC CPU, 166MHz
RAM	64MB SDRAM
Flash	4MB
CF-Slot	True IDE mode (accepts MicroDrives)
microSD-Slot	1 x internal
USB	2 x 2.0 as Host
LAN	10baseT/100baseTX Autodetect and Auto-MDI(X)
Serial Ports	2 x RS232/RS422/RS485 up to 3.6Mbps 2 x RS232 up to 921,6Kbps
CAN ports	1 x SJA1000 up to 1Mbps
Digital I/O	4 x input/output signals (32 mA max.) 2 x optically isolated input channels 2 x relays
Console Port	RS232, up to 115200bps
I ² C	max. 330kHz
RTC	yes
Buzzer	yes
Watch Dog Timer	yes
MiniPCI-Slot	yes
Reset Button	HW Reset, long hold to access BIOS via Telnet
Power Input	9-30V DC
Power Consumption	max. 1.5A @ 12V
Dimensions (W x L x H)	157 x 106 x 53 mm 157 x 112 x 53 mm with DB9 connector

Table 1: Product Hardware Specifications

1.2.2 Serial Ports

Two serial ports are provided in RS232/422/485 modes that can be switched by software. For the detailed information about the supported modes refer to the Table 2.

	RS232	RS422	RS485
Modes	full duplex	full duplex	2-wire: half duplex, with echo 2-wire: half duplex, without echo 4-wire: full duplex
Signals	TxD, RxD, RTS, CTS, DTR, DSR, DCD, RI, GND	Tx+/-, Rx+/-, GND	2-wire: Data+/-, GND 4-wire: Tx+/-, Rx+/-, GND
Data Direction Control			by ART (Automatic Receive Transmit control) or by RTS
Speed	up to 921.6 Kbps	up to 3.6 Mbps	up to 3.6 Mbps

Table 2: Serial Interface Specifications

1.2.3 Digital I/O

Four input/output signals at TTL level are provided. The signal direction is individually configurable. Each signal carries up to 32mA in both directions. For input mode the change of at least one input signal generates an interrupt.

2 Position of Connectors and Functions

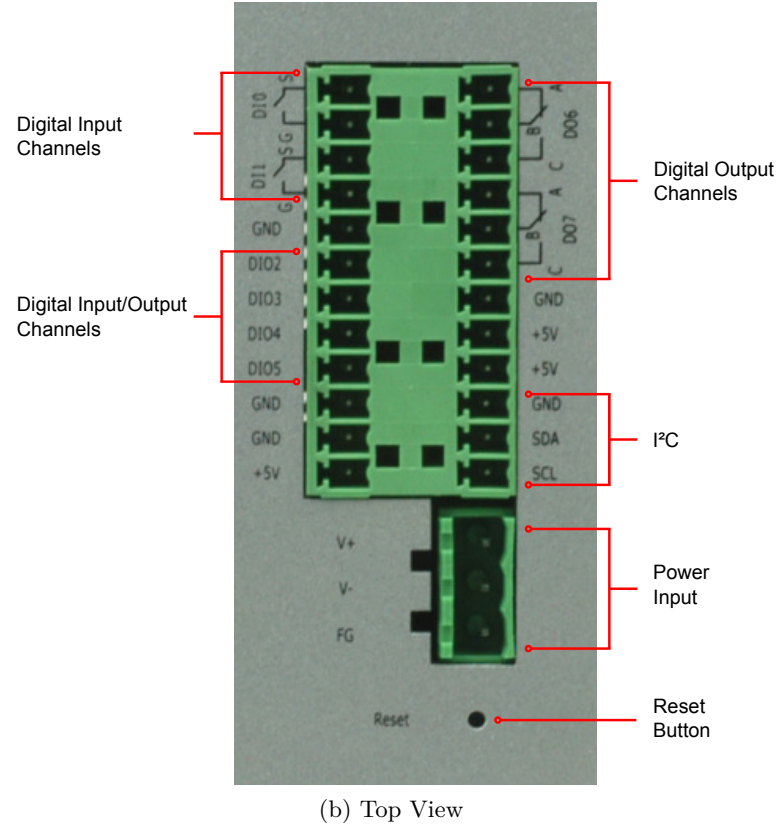
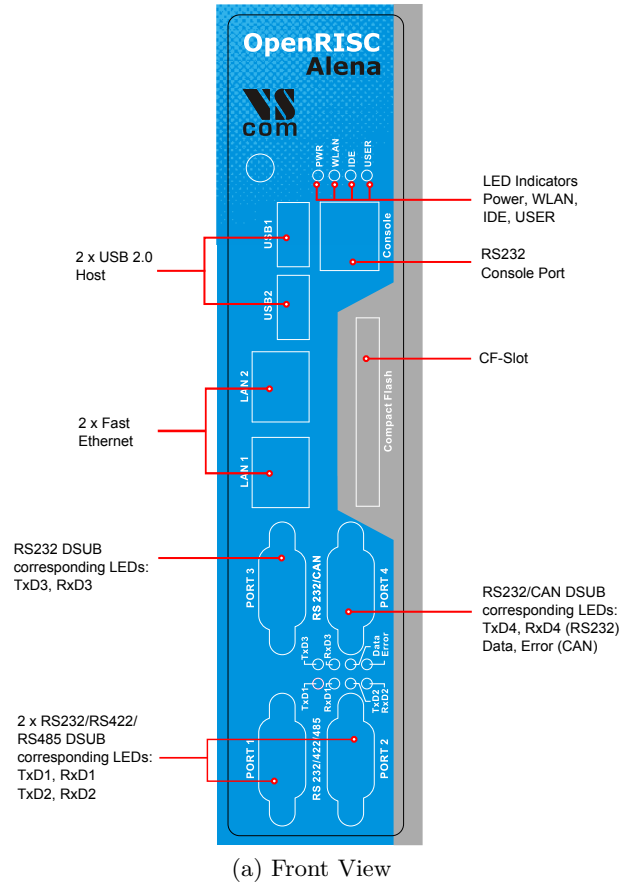

Figure 1: Appearance

2.1 LEDs

Name	Color	Description
POWER	Red	Power is on
WLAN	Blue	WLAN card has a connection to AP
IDE	Yellow	CF is in use
USER	Green	Customizable
LAN1, LAN2	Yellow Green	Ethernet connection established, blinks with traffic On if 100 Mbps link
TxD1, TxD2, TxD3	Green	Transmit traffic
RxD1, RxD2, RxD3	Yellow	Receive traffic
Data	Green	CAN traffic (shared with TxD4)
Error	Yellow	CAN errors (shared with RxD4)

Table 3: LED Indicators

2.2 Reset Button

With Reset button you can restart the OnRISC Alena without removing the power. It can be also used to get in BIOS via Telnet (see Table 1). For further information refer to the “OnRISC User Manual” section “BIOS”. The Reset button should be used only in situations, where reboot command is not available, to avoid filesystem integrity errors.

3 Dimensions

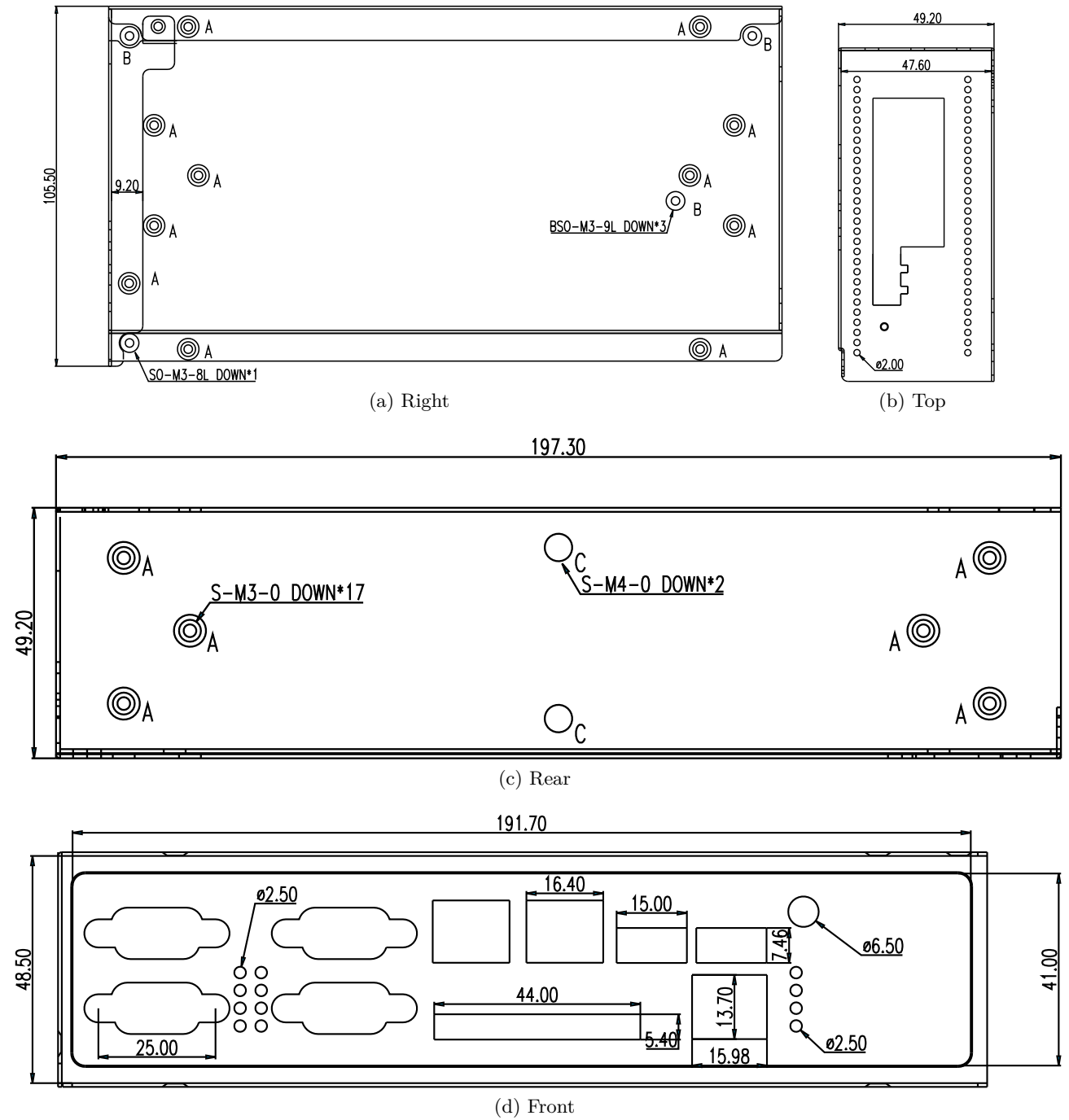

Figure 2: Case

4 Connectors

4.1 Power

The OnRISC Alena device is powered by a single power supply in a wide range from 9V DC to 30V DC. A suitable power supply adapter is part of the packaging list. Connect the cable to the power jack at the top side of OnRISC Alena, and put the adapter into the socket. The Power LED (red) on OnRISC Alena will light. You can connect a power supply of your choice, providing the technical requirements are met.

Warning: disconnect the OnRISC Alena before performing installation or wiring. The wire size must follow the maximum current specifications. The maximum possible current in the power wires as well as in the common wires must be taken under consideration. If the current rises above the maximum ratings, the wiring can overheat, causing serious damage to your equipment. When powered, the OnRISC Alena's internal components generate heat, and consequently the outer case may feel warm to the touch.

4.2 Grounding

Grounding and wire routing help limit the effects of noise due to electromagnetic interference (EMI). Run the ground connection from the ground screw to the grounding surface prior to connecting devices.

4.3 LAN

The connectors for Ethernet are the usual RJ45. Simply connect them to your switch or hub. When the connect is done the Link LED on RJ45 (yellow) will light. When data traffic occurs on the network, this LED will blink. It depends on your network whether a 100Mbit or a 10Mbit connect will be established. A 100Mbit net causes the Speed LED on RJ45 (green) to light, otherwise it will remain dark. Both Ethernet interfaces support Auto-MDI(X) feature.

4.4 Serial

The OnRISC Alena has four DSUB 9 male connectors. All three modes of operating RS232, RS422 or RS485 are entirely configured by software. For the pinout refer to the Table 4.

Please note the function of the GND signal in RS422 and RS485 modes: this signal must also be connected between the serial devices. So in reality a 2-wire and a 4-wire connection need 3 wire and 5 wire respectively. With the exception of very special configurations, a serial connection in RS422/RS485 mode without GND connection violates the specifications for RS422 and RS485 standards.

4.5 CAN

The OnRISC Alena provides one CAN interface with a DSUB 9 male connector (PORT4) that is shared with the fourth serial port (see Table 4 for pinout). The physical drivers will be switched between CAN and RS232 per software.

Pin	RS232	RS422	RS485 2wire	CAN
1	DCD	Tx- (A)	Data- (A)	
2	RxD	Tx+ (B)	Data+ (B)	CANL
3	TxD	Rx+ (B)		GND
4	DTR	Rx- (A)		
5	GND	GND	GND	
6	DSR			
7	RTS			CANH
8	CTS			
9	RI			

Table 4: DSUB Pinout

4.6 Console Port

The console port (RS232) has an RJ45 connector. An adapter cable to DB9 male is provided. The pinout of the DB9 male connector is the same as PORT1-4 in RS232 mode, without signal RI.

4.7 CF-Slot

The CF-Slot supports True IDE mode for storage expansion. The memory size of the CF-Card is not limited. For use with the prepared Debian Linux image it is recommended to use at least 1GB CompactFlash. MicroDrives can be also used.

4.8 microSD-Slot

The OnRISC Alena provides one microSD-Slot inside the case so it is not accessible from outside. This slot can be used in the same way as CF-Slot to store the system or it can be used as extra storage device.

4.9 USB

The OnRISC Alena provides two USB 2.0 Host interfaces. They can be used for Mass Storage Devices, like Flash- or Hard Drive, Bluetooth and WLAN adapters etc.

4.10 Digital I/O

The OnRISC Alena provides 4 digital input/output channels, 2 optically isolated digital input channels and 2 relays. The data direction for each I/O channel can be independently set to input or output. An interrupt for an input channel can also be independently enabled to detect signal level changes. The physical driver operates with 32mA for both high and low level.

4.11 I²C

The I²C interface operates at the maximum frequency of 330 KHz. The connector for I²C is located on the terminal digital I/O block and has three pins: SCL, SDA and GND. When required the I²C device can be powered with the VCC output of the digital I/O terminal block.

5 Product Support Information

The following services are provided on www.vscom.de and www.visionsystems.de for the customers to support our products:

- driver updates
- product information
- user's manual updates

For special technical support issues please use our FAQ system faq.visionsystems.de.